

CREEP FURNACE 1300°C ADAMEL TYPE

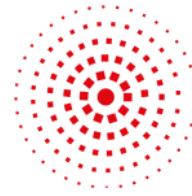

AET
TECHNOLOGIES

ADAMEL machines still represent the majority of the creep machines installed in Western Europe. Our replacement solution for ADAMEL type creep furnaces allows you to work well above 1100°C (current limit of furnaces for long cycle periods).



ABOUT US

AET Technologies is the European leader on the hot mechanical testing market.

Our engineering know-how concerning heating and mechanical transfer, management of gases-atmospheres as well as vacuum, automatism and regulation allows us to give you a perfect answer adapted to your needs.

Autonomous or integrated furnaces, dedicated to production or to R&D, we deliver turnkey equipment, thanks to unique engineering and recognized experience.

David D'ATTOMA
Chief Sales Officer

✓ A turnkey equipment

Adaptable on all creep machines with minimum centre spacing (250mm for diameter of 50mm) between columns for retrofit of ADAMEL type furnaces with mounting rings.

✓ ISO 204-2023 standard

We conform to this standard that specifies the method for uninterrupted or interrupted creep tests and defines in particular the temperature homogeneity and gradients to be respected.

✓ Removable heating elements

Lanthanum chromite heating elements can be replaced without disassembly of the load column thus insuring test continuity.



Let's innovate together to reinvent today's materials and discover tomorrow's.

AET GROUP
73D rue Général Mangin
38100 Grenoble - FRANCE

sales@aet.group
+33 (0)4 76 90 41 18

CREEP FURNACE 1300°C ADAMEL TYPE

A technical solution that can be powered by 230V, without transformer, in order to optimize the cost of the electrical box.

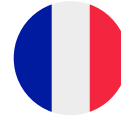

Made in
France



After-sales
service



Recognition
of excellence



Key elements

- **FULLY COMPATIBLE WITH ADAMEL TYPE CREEP FURNACE**
Compatible with current ADAMEL machines. Fits perfectly into a 250mm column spacing.
- **INNOVATIVE TECHNOLOGY**
The result of a unique R&D work, the lanthanum chromite technology is the sole property of AET Technologies.
- **100% NON-CARCINOGENIC MATERIALS**
Removes the risk of users being exposed to a dangerous substance (Directive 97/69/EC).

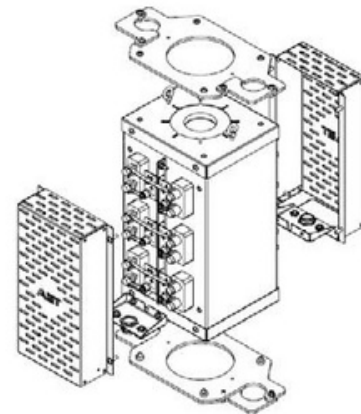

Technical specifications

- 1300°C continuously
- Heating rate 5°C/min
- Natural cooling rate
- Power: 4 kW
- Thermal regulation on the furnace or on the specimen
- Ceramic tube C530 Ø65mm interior maximum
- Homogeneous heating height 190mm maximum
- 3 heating zones controlled by setpoint shift
- Dimensions: width 220mm, overall height 470mm
- HMI interface: 5 or 7-inch color touchscreen
- USB front panel for CSV file, wifi or Ethernet connection



Let's innovate together to reinvent
today's materials and discover
tomorrow's.

AET GROUP

73D rue Général Mangin
38100 Grenoble - FRANCE

sales@aet.group
+33 (0)4 76 90 41 18